

KRIFF K3 LED

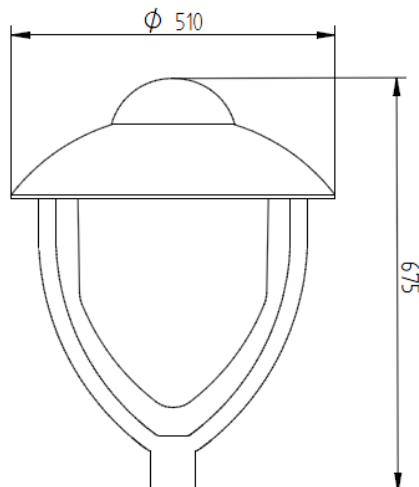

Korpus	Blacha stalowa ocynkowana, malowana proszkowo
Klosz	Vivac bezbarwny
Stopień szczelności	IP65
Klasa ochronności	Klasa I
Montaż	Na słupie Ø60 mm
Zastosowanie	Tereny miejskie, parki, chodniki, ulice o niskim natężeniu ruchu

Nazwa oprawy	Moduł LED	Moc	Strumień świetlny	Efektywność	Temperatura barwowa	Współczynnik Ra	Waga
Kriff KL LED DLM 2000 830	Fortimo LED DLM Gen 5	25 W	2000 lm	81 lm/W	3000 K	80	12 kg
Kriff KL LED DLM 2000 840	Fortimo LED DLM Gen 5	22 W	2000 lm	90 lm/W	4000 K	80	12 kg
Kriff KL LED DLM 3000 830	Fortimo LED DLM Gen 5	37 W	3000 lm	81 lm/W	3000 K	80	12 kg
Kriff KL LED DLM 3000 840	Fortimo LED DLM Gen 5	34 W	3000 lm	89 lm/W	4000 K	80	12 kg
Kriff KL LED LLM 1800 730	Fortim o LED LLM Gen 3	23 W	1800 lm	78 lm/W	3000 K	70	12 kg
Kriff KL LED LLM 1800 740	Fortim o LED LLM Gen 3	21 W	1800 lm	86 lm/W	4000 K	70	12 kg
Kriff KL LED LLM 3000 730	Fortim o LED LLM Gen 3	37 W	3000 lm	81 lm/W	3000 K	70	12 kg
Kriff KL LED LLM 3000 740	Fortim o LED LLM Gen 3	34 W	3000 lm	88 lm/W	4000 K	70	12 kg
Kriff KL LED LLM 4500 730	Fortim o LED LLM Gen 3	52 W	4500 lm	87 lm/W	3000 K	70	12 kg
Kriff KL LED LLM 4500 740	Fortim o LED LLM Gen 3	48 W	4500 lm	94 lm/W	4000 K	70	12 kg
Kriff KL LED FF 2000 740	FastFlex LED board 2x8	19 W	2124 lm	112 lm/W	4000 K	70	12 kg
Kriff KL LED FF 2000 840	FastFlex LED board 2x8	19 W	2006 lm	106 lm/W	4000 K	80	12 kg
Kriff KL LED FF 3000 740	FastFlex LED board 2x8	27 W	3036 lm	112 lm/W	4000 K	70	12 kg
Kriff KL LED FF 3000 840	FastFlex LED board 2x8	27 W	2870 lm	106 lm/W	4000 K	80	12 kg
Kriff KL LED FF 5000 740	FastFlex LED board 2x8	49 W	5039 lm	103 lm/W	4000 K	70	12 kg
Kriff KL LED FF 5000 840	FastFlex LED board 2x8	49 W	4763 lm	97 lm/W	4000 K	80	12 kg

